

FSF

Automatic screwdriver for flowdrilling screws with automatic feeding



Our automatic screwdriver for fitting flow drilling screws has been specially developed for use in the automotive industry. Different materials with thicknesses of up to 5 mm each can be connected to each other. The system can be used stationary or on robots. The drive for the axial movement is situated directly above the screwing tool. The force is therefore initiated centrally over the screw. This means that only very small masses are moved, leverage effects are eliminated. When feeding the screws, the customer can choose between direct feed and magazine-loaded feed with automatic or manual filling. In all variants, the screw is always fed forwards with the screw head and only turned briefly in front of the feeding head in order to preserve the screw tips. The controller monitors and documents all screw parameters.



THE ADVANTAGES AT A GLANCE:

- + Fully monitored system with monitoring and documentation of all screw parameters: Torque, rotational angle, screw-in depth, force, contact pressure
- + Immediate identification and reporting of any incorrect assemblies
- + Screw parameters can be individually parametrized per screw location
- + Compact design for hard-to-access screw locations
- + Fast bit change without tools
- + Feed head can be removed without auxiliary tools
- + Feed arm can be changed without auxiliary tools
- + Very low moving masses
- + Automatic feeding of the screws
- + Magazine on the automatic screwdriver with separate filling station
- + Gentle feeding principle
- + Compact working radius of clamping surface to the screw axis, beneficial robot lever arm
- + Can be used as a robot solution in any position

Modules

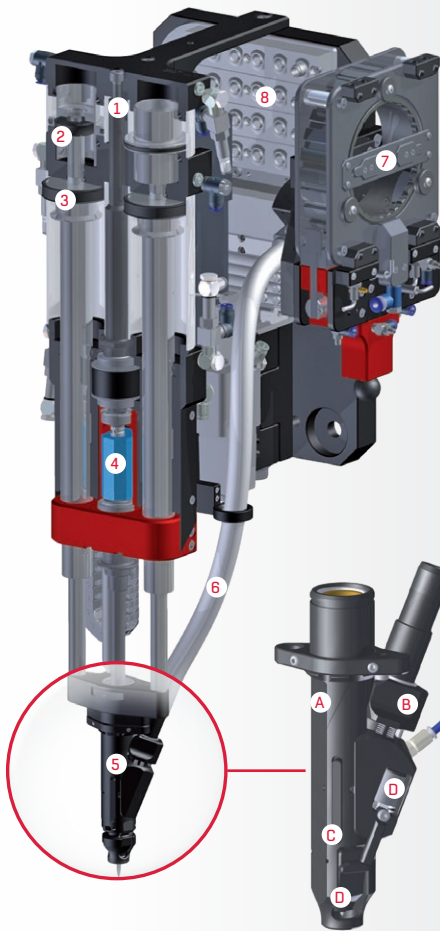

- 1 NOK stroke
- 2 Feed stroke
- 3 Tool stroke
- 4 Torque sensor
- 5 Screwdriving head
- 6 Feed hose
- 7 Magazine (optional)
- 8 Clamping surface

Nozzle

- A Flattened outline for optimum accessibility to interfering contours.
- B Quick release for easy change of feeding arm
- C Locking jaws for over-head screw connections
- D Two jaws: Safe „finding“ of the driving characteristic by actively clamping the screw



Centering aid

- To teach the fastening points
- No lifting movements required
- Teaching when de-energized for increased safety
- Integrated predetermined breaking point prevents collision damages

Predetermined breaking point

Spring-loaded centering pin

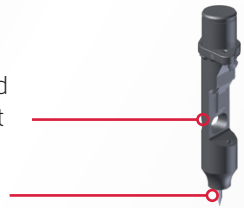

Direct feed

A screw unit with direct feed is available as an alternative to the magazine design. Later conversions are also possible. The same feeder unit is used for both versions.

Interfering contours

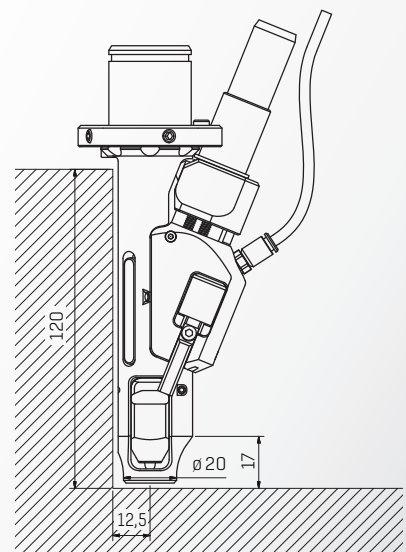

- Max. interference contour height 120 mm
- Spacing interference contour - screw centre 12.5 mm
- Nozzle tip \varnothing 20 mm

Technical Data

Dimensions L x W x D with magazine	750 x 350 x 280 mm
Dimensions L x W x D without magazine	750 x 320 x 280 mm
Tool contact pressure	< 3,300 N
Retaining device contact pressure	< 1,200 N
Rpm	5,100 min ⁻¹
Torque	max. 15 Nm
Weight	approx. 45 kg
Cycle time	2.7 - 3.5 sec. (depending on the sheet combination)
Compressed air supply	6 bar
Necessary lines	6
Max. cable length	60 m
Tool stroke	120 mm
Feed stroke (retaining device)	30 mm
NOK stroke (eject screw)	20 mm

Feed unit

Modules

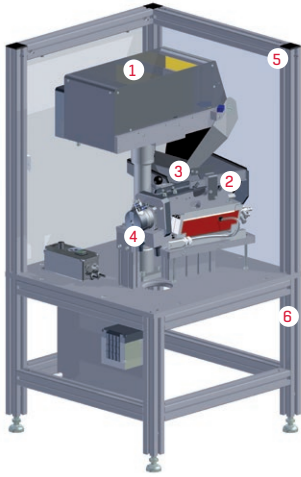

Advantages

- + Compact
- + Vibration-free sorting container
- + Gentle feeding principle

- 1 Hopper
- 2 Step feeder
- 3 Fill level control
- 4 Separator
- 5 Acoustic cover
- 6 Base frame

Technical Data

Dimensions (WxDxH)	600 x 600 x 1150 mm
Conveying speed	max. 40 pcs./min
Fitting quantity	10 litres

Magazine handling

Filling station

1. The screw unit is automatically positioned to the change position.
2. Empty magazine is removed.
3. Swivel device is turned by 180°.
4. Full magazine is transferred.
5. Empty magazine is refilled.

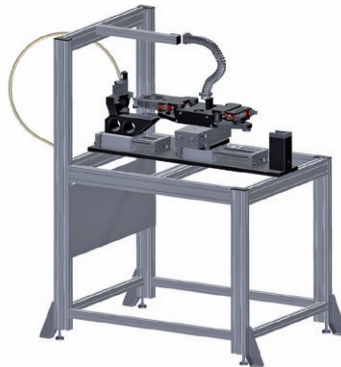

Direct feed

- A** Feed screw forward with head
- B** Rotate the swivel device by 90°
- C** Feed the screw forward with tip in nozzle
- D** Swivel device moves to the starting position while the new screw is fed

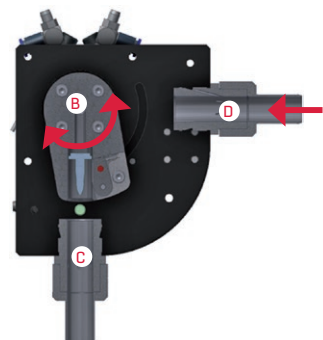
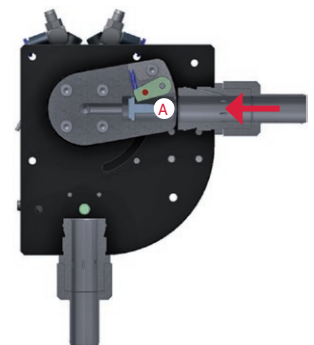

Filling station	
Dimensions (WxDxH)	1200 x 900 x 1650 mm
Filling speed	40 sec./magazine

Magazine with 27 chambers	
Dimensions (WxDxH)	120 x 120 x 63 mm
up to 9 codes can be mechanically coded; for different screws to avoid confusion	



The screw unit is initially aligned to the magazine changing position. A positioning aid is available for this purpose.

Controller

- + Cabinet housing individually selectable
- + 15" touch display
- + Open program structure
- + Up to 4 screwdriving systems with feed unit can be controlled
- + Interface to various bus systems
- + Evaluation of all process parameters
- + Up to 1,000 screwdriving programs
- + Docking mode for robot use



Faster bit change without auxiliary tools



Hanging the feed arm out



Removing the feed arm



Unlocking and removing bit

Complete system overview



Screw unit (on robot arm)



Filling station

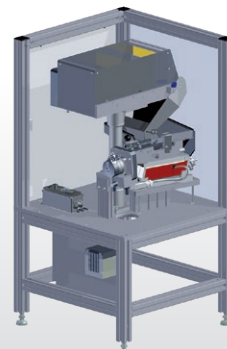

Feed unit



Controller

CAD data available on www.stoeger.com/en/downloads.html under file "automatic screwdrivers"

STÖGER AUTOMATION GmbH
 Gewerbering am Brand 1
 82549 Königsdorf

Phone: +49 8179 997 67-0
info@stoeger.com
www.stoeger.com

